

NA / NB series

Circular VAV and CAV air volume control terminals

HC BARCOL-AIR

Description	Page
Type designation	1
Technical data	
- General	2
- Specification	3
- Installation instruction	3
Model overview / dimensions	4 - 5
Sound data NAOB... / NBOB...	6 - 7
Sound data NAOC... / NBOC...	8 - 9
Sound data NAOG... / NBOG... / NAON... / NBON...	10 - 11
Sound data NAOJ... / NBOJ... / NAOQ... / NBOQ...	12 - 13

Circular VAV and CAV air volume control terminals

Type designation
NA / NB

Composition type designation:

N - B - O - N - E - O - B

N Position 1: **Product group**

N = air volume control terminals

B Position 2: **Function**

A = single wall, circular volume control terminal
B = double wall, circular volume control terminal
1 = non standard, specify separately

O Position 3: **Controls (manufacturer)**

O = without controls
For controls, contact our sales staff

Q Position 4: **Outlet**

A = rectangular outlet
B = circular outlet
C = 4 circular outlets ('Octopus')
G = rectangular outlet and provision for integral hot water reheat coil
J = 4 circular outlets and provision for integral hot water reheat coil
N = rectangular outlet and provision for integral electric reheat coil
Q = 4 circular outlets and provision for integral electric reheat coil
1 = non standard, specify separately

E Position 5: **Reheat coil**

O = without reheat coil
A = 1-row hot water reheat coil
B = 2-row hot water reheat coil
D = 4-row hot water reheat coil
E = 1-stage 230VAC/1-phase electric reheat coil
F = 2-stage 230VAC/1-phase electric reheat coil
G = 3-stage 230VAC/1-phase electric reheat coil
H = 1-stage 400VAC/3-phase electric reheat coil
J = 2-stage 400VAC/3-phase electric reheat coil
1 = non standard, specify separately

O Position 6: **Controls (type & function)**

O = without controls
For controls, contact our sales staff

B Position 7: **Sensor**

O = not applicable
B = Flo-Cross®, 2 x 12 point averaging and signal amplifying air flow sensor (standard)
1 = non standard, specify separately

Ordering example:

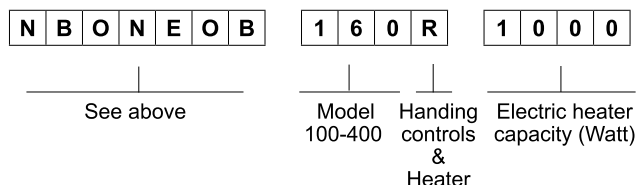

Ordering codes "Specials"

N..1... - 3010 = 4 balancing dampers in 'Octopus' outlet
N..1... - 3006 = 'Octopus' with 6 outlets instead of 4
N..1... - 3016 = 'Octopus' with 6 outlets incl. balancing dampers
N..1... - FL = Flange connection 30 mm for rectangular outlet

Ordering information:

Standard terminals:

- quantity of terminals
- complete 7 digit code
- terminal size or model
- air volume setting (V_{max} , V_{min} etc)
- control handing (standard right side)
- if applicable, electric reheat coil capacity
- supply or return air

Non standard terminals:

- for non standard terminals a full description and/or drawing are requested

Circular VAV and CAV air volume control terminals

Technical data
Single wall (NA.....)
Double wall (NB.....)



Application

Types NA and NB are circular pressure-independent VAV and CAV air volume control terminals. The terminals are designed particularly for systems with space and installation restrictions and for the accurate measurement and control of air volumes courtesy of the patented airflow sensor type Flo-Cross®.

In CAV application, the terminals maintain the required constant airflow independent to the inlet static pressure.

In VAV application, the terminals control the air volume to the room, depending on the cooling load required thus saving energy consumption in both cooling and heating applications.

Alternatively VAV terminals are ideal to be used for CO₂ control. Dependent of the indoor air quality, always the correct amount of fresh air will be supplied to the room. Of course the primary air handling system need to be suitable for this.

The VAV or CAV terminals can be used either for supply or return air applications in new or refurbishment projects. The terminals do have a single wall (NA) or double wall (NB) construction and can be delivered with a distribution plenum and a built-in hot water or electric reheat coil.

Features:

- Pressure independent control functions.
- Volume control range 100% down to 10%.
- Low pressure loss over the terminal.
- Single or double wall construction.
- Factory fitted distribution plenum with built-in hot water or electric reheat coil.
- Oval shaped damper blade for linear control characteristics.
- Low leakage damper, less than 2% of Vnom at 750 Pa.
- Low noise production.
- Suitable for all control functions (VAV, CAV, shut-off, etc.) to maximise system energy savings.
- Flo-Cross® 2 x 12 points averaging and signal amplifying airflow sensor, better than 2,5% accuracy even with irregular duct approach.
- Maintenance free.

Technical information

Casing:

Single or double wall, air-tight construction made of galvanized sheet steel (non spiral), casing leakage rate to Class II VDI 3803 or DIN 24 194 part 2. Duct-sleeve connections at the in- and outlet are suitable for DIN 24 145 or DIN 24 146 connections. In case of double wall construction 25 mm insulation material is used, completely enclosed by the double wall construction.

Insulation:

The terminal is supplied with 25 mm thermal and acoustical insulation (30 kg/m³) complying to: NFPA90A and 90B surface burning characteristics, BS476 part 6 and 7 fire propagation, UL 181 class 0 surface spread of flame and UL 94 HF1 flamability.

Damper:

Damper blade: made of steel, sandwich construction of twin blade and neoprene gasket with low leakage according to DIN 1946, part 4. Damper shaft: aluminium, ø12 mm with self lubricating Nylon bearings.

Flo-Cross®:

Extruded aluminium construction with nylon core + feet.

Distribution plenum:

Made of galvanized sheet steel with 13 mm internal isolation. Plenum with standard rectangular or multiple (4 x circular) outlet construction. Optional single, double, triple or six circular outlets are possible. Outlet spigots are made of flame retardant polymer and optionally can be provided with volume control dampers made of galvanized sheet steel.

Reheat coil:

Choice of 1-, 2- or 4-row hot water reheat coil or electric reheat coil (230VAC/1-phase or 400VAC/3-phase).

More detailed technical information can be found in the separate NO documentation.

Controls:

Suitable for use with pneumatic, analogue electronic or DDC controllers. Controls can be factory fitted, wired and calibrated. Controls enclosure (galvanized sheet steel) can be provided optionally.

Delivery format

Delivery format:

- The VAV or CAV terminal will be supplied as a single mounting assembly. Optional ordered distribution plenum, reheat coil and/or controls are factory fitted, wired and calibrated. The on site delivered terminal can directly be installed and commissioned.
- Controls location and hot water or electric connections are as a standard fitted on the right hand side of the terminal when looking in the direction of the airflow.
- On request, the terminal can be delivered with connections on the left hand side.
- When terminals are ordered with controls, these will be factory fitted, wired and calibrated upon request.
- For terminals ordered with 'free-issue' third party controls, wiring diagrams and mounting instructions must be provided.

Circular VAV and CAV air volume control terminals

Technical data
Single wall (NA.....)
Double wall (NB.....)

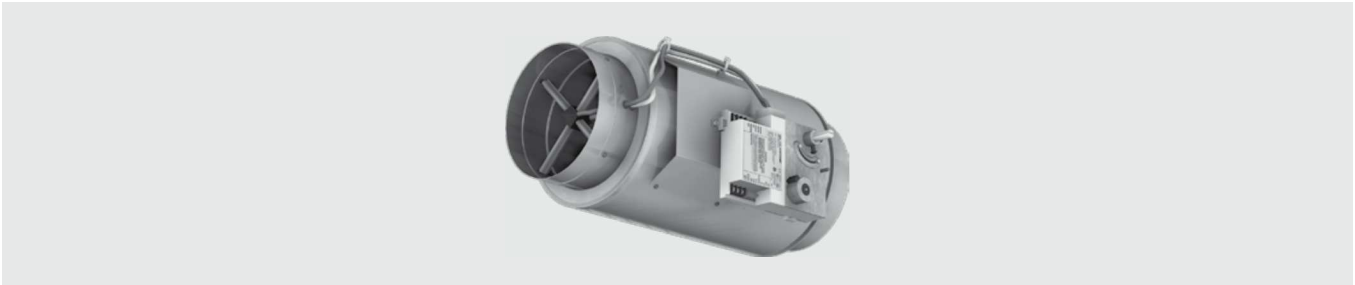

Specify as:

Example:

Supply and install, variable air volume terminals, double-wall construction with distribution plenum with 4 circular outlets, constructed from galvanized sheet steel. The casing leakage rate shall be classified according to class II, VDI 3803/DIN 24 194 and the duct-sleeve connections shall be suitable for DIN 24 145 or DIN 24 146 respectively. The VAV terminals shall have a low leakage, sandwich construction and oval shaped damper blade with neoprene gasket and an aluminium damper shaft with self lubricating Nylon bearings.

A centre averaging airflow sensor with at least 2 x 12 test points and amplified signal, type Flo-Cross® shall control the airflow with an accuracy better than 2.5 %. The terminals shall be supplied with 1-row hot water reheat coil.

The controller shall be I/A Series, DDC controller:
LonMark® compatible, type MNL-V2RVx or
BACnet® compatible, type MNB-V2.

Controls must be factory fitted, wired and calibrated according to the following requirements:

- Maximum air volume 250 l/s
- Minimum air volume 60 l/s
- Minimum air volume 120 l/s (in case of reheat)
- Terminal size 200 mm
- Max. pressure loss 38 Pa
- Max. discharge sound index < NC30 (@250Pa Δp)
- Max. radiated sound index < NC30 (@250Pa Δp)

Ordering example: type – model – handing
= NBOJAOB – 200R

Manufacturer: HC Barcol-Air

Installation Instructions:

The HC Barcol-Air VAV terminals shall be installed using at least two support brackets (DIN-rail or L-profile), with anti-vibration rubber under the terminal. Each of these brackets shall be fixed with two threaded rods to the ceiling slab above.

This installation method:

- 1 Shall prevent the body of the VAV terminal from high mechanical tension, which could damage the construction and performance of the terminal.
- 2 Shall prevent torsion on the VAV terminals, which could cause malfunction of the damper blades.
- 3 Provides some flexibility to the final location of the VAV terminals.
- 4 Use at least 1x diameter straight duct length before the VAV inlet.

- 5 Additional manual volume control dampers (VCD's) before the inlet are not required / recommended!!
6. All connections shall be thermally isolated.
7. Pressure sensing tubes of Flo-Cross® airflow sensor shall not be "kinked" or otherwise obstructed by the external duct insulation.

Installation of circular VAV terminals can be done in a similar way, with the only assumption that two circular support brackets with anti-vibration rubber (installation clamps) instead of DIN-rail or L-profile shall be used. To prevent the VAV terminal from rotation, we recommend to use a complete clamp (support + top bracket), so that the terminal is 'clammed' in between.

Optional 4 x Mupro fixing hooks can be used (see drawing).

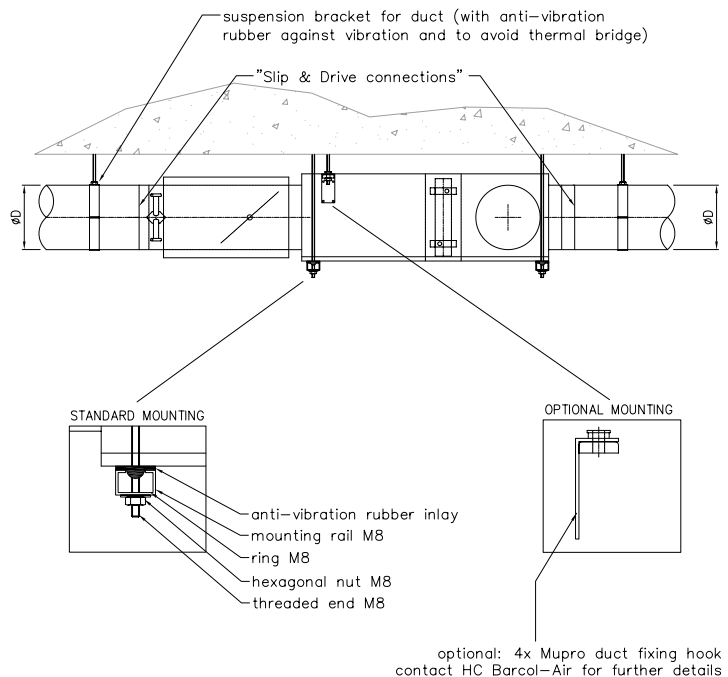

Circular VAV and CAV air volume control terminals

Model overview Single wall - type NA.....

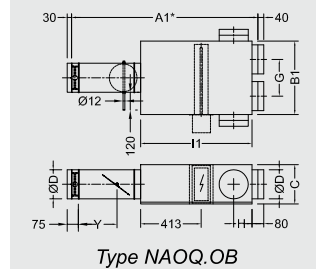
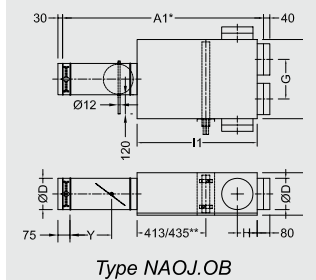
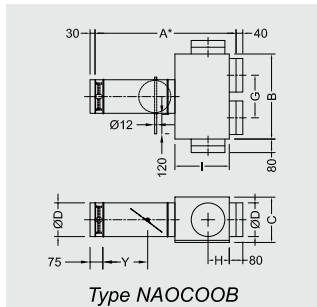
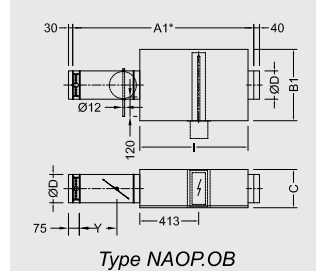
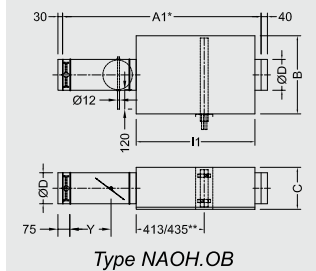
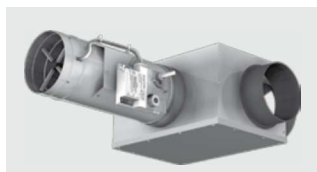
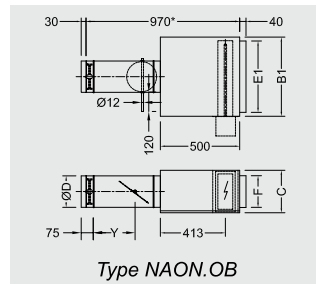
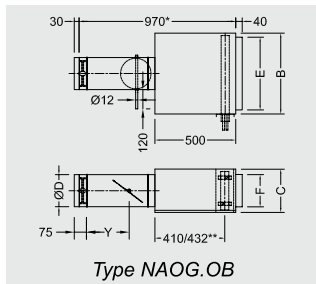
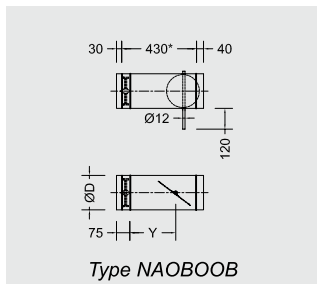
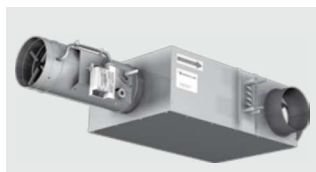

Dimensions NA terminals

Model	100	125	160	200	250	315	355	400
A*	780	780	780	830	880	930	990	1030
A1*	1230	1230	1230	1280	1330	1380	1440	1480
B	330	330	400	500	600	740	820	910
B1	330	330	400	400	600	600	600	600
C	228	228	248	268	318	408	408	458
ØD	98	123	158	198	248	313	353	398
E	275	275	350	450	550	690	770	850
E1	275	275	350	350	550	550	550	550
F	170	170	175	200	250	330	330	380
G	180	180	215	255	305	370	410	455
H	125	125	125	125	175	200	250	250
I	270	270	270	320	370	420	520	520
I1	720	720	720	770	820	870	970	970
Y	310	310	310	300	285	260	245	235

Other dimensions are available upon request.

Kv values

Model	100	125	160	200	250	315	355	400
Kv (l/s / Pa)	5,5	8,5	15,0	24,9	35,4	58,9	74,3	92,6

All dimensions in mm.

* = Installed length.

** = Size varies with a 1-2-row or 4-row hot water reheat coil.

Flow = $K_v \times \sqrt{\Delta P_{fc}}$
 ΔP_{fc} = Flo-Cross® signal
 If ΔP_{fc} = 30 Pa and VAV size = 160
 Flow = $15,0 \times \sqrt{30} = 82$ l/s

Circular VAV and CAV air volume control terminals

Model overview Double wall - type NB.....

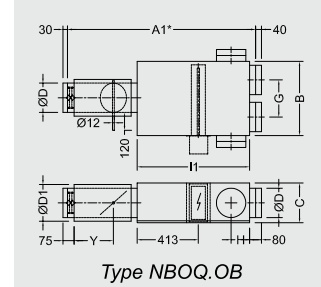
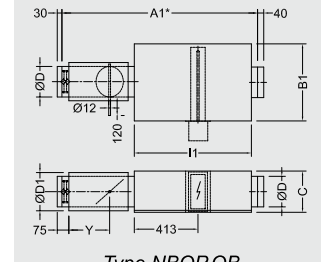
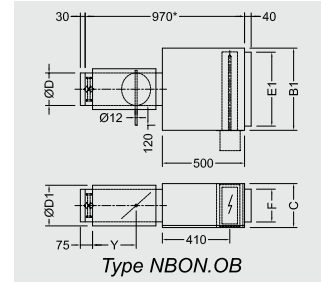
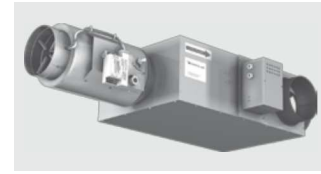
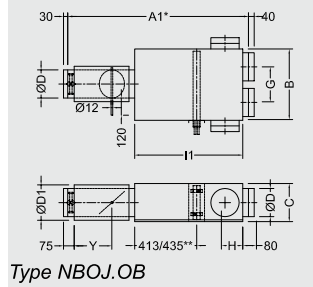
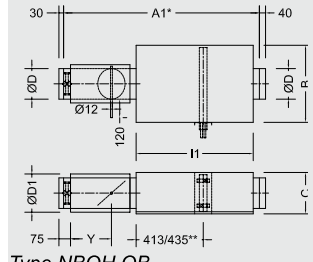
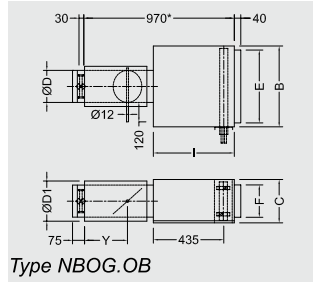
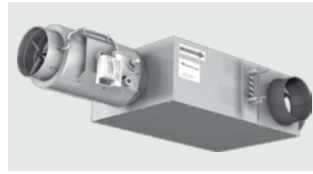
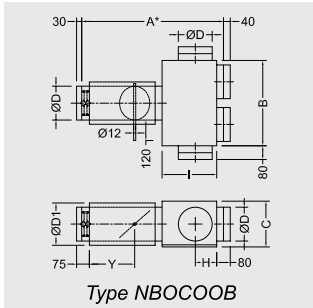
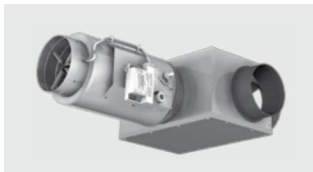
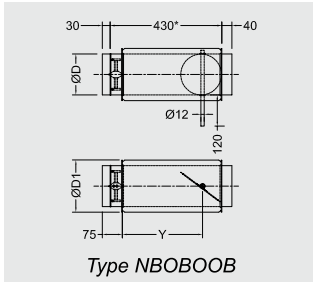

Dimensions NB terminals

Model	100	125	160	200	250	315	355	400
A*	780	780	780	830	880	930	990	1030
A1**	1230	1230	1230	1280	1330	1380	1440	1480
B	330	330	400	500	600	740	820	910
B1	330	330	400	400	600	600	600	600
C	228	228	248	268	318	408	408	458
ØD	98	123	158	198	248	313	353	398
ØD1	150	180	200	250	300	355	400	450
E	275	275	350	450	550	690	770	850
E1	275	275	350	350	550	550	550	550
F	170	170	175	200	250	330	330	380
G	180	180	215	255	305	370	410	455
H	125	125	125	125	175	200	250	250
I	270	270	270	320	370	420	520	520
I1	720	720	720	770	820	870	970	970
Y	310	310	310	300	285	260	245	235

Other dimensions are available upon request.

Kv values

Model	100	125	160	200	250	315	355	400
Kv (l/s / Pa)	5,5	8,5	15,0	24,9	35,4	58,9	74,3	92,6

All dimensions in mm.

* = Installed length.

** = Size varies with a 1-/2-row or 4-row hot water reheat coil.

Flow = Kv x √ΔPfc
 ΔPfc = Flo-Cross® signal
 If ΔPfc = 30 Pa and VAV size = 160
 Flow = 15,0 x √30 = 82 l/s

Circular VAV and CAV air volume control terminals

Type **NAOBOOB**
NBOBOOB

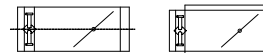

Sound data $\Delta p = 125 \text{ Pa}$

Model	data referring to inlet spigot				min. Δp_s	$\Delta p = 125 \text{ Pa}$																										
						discharge sound						radiated sound single wall						radiated sound double wall														
	air volume					L_w in dB/Oct. (re 1pW)						Lp values			L_w in dB/Oct. (re 1pW)						Lp values			L_w in dB/Oct. (re 1pW)						Lp values		
						125 Hz	250 Hz	500 Hz	1000 Hz	2000 Hz	4000 Hz	dB(A)	NC	NR	125 Hz	250 Hz	500 Hz	1000 Hz	2000 Hz	4000 Hz	dB(A)	NC	NR	125 Hz	250 Hz	500 Hz	1000 Hz	2000 Hz	4000 Hz	dB(A)	NC	NR
m/s	l/s	CFM	m ³ /h	Pa	dB						dB						dB															
100	2	15	31	53	2	43	44	40	38	34	22	--	--	--	19	-	19	20	23	21	--	--	--	-	-	-	-	-	-	--	--	--
	4	29	62	106	8	49	50	46	44	40	29	24	--	20	26	23	26	27	30	28	--	--	--	22	-	-	-	-	-	--	--	--
	6	44	94	160	17	53	54	51	48	44	34	28	22	24	30	27	30	31	34	32	--	--	--	26	20	-	-	-	-	18	--	--
	8	59	125	213	30	57	58	54	52	49	39	31	26	28	33	30	33	34	37	35	--	--	--	29	23	19	19	19	21	--	--	--
10	74	156	266	47	59	61	58	55	52	43	34	29	31	35	32	35	36	39	37	--	--	--	32	26	22	21	21	23	--	--	--	
125	2	23	49	84	2	40	43	40	39	34	25	--	--	--	28	24	25	22	23	17	--	--	--	-	-	-	-	-	--	--	--	
	4	47	99	168	7	47	49	46	45	40	31	23	--	--	35	31	32	29	30	24	--	--	--	23	18	-	-	-	-	--	--	--
	6	70	149	253	16	52	54	51	49	44	36	27	21	24	39	35	36	33	34	28	--	--	--	27	22	19	18	-	19	--	--	--
	8	94	198	337	28	56	58	55	53	48	40	31	25	28	42	38	38	35	37	31	21	--	--	30	25	22	21	20	22	--	--	--
10	117	248	421	44	59	61	58	56	51	44	34	29	31	44	40	41	38	39	33	23	--	--	33	28	25	23	22	24	--	--	--	
160	2	39	82	139	2	39	41	40	38	37	32	--	--	--	28	24	25	22	23	18	--	--	--	18	-	-	-	-	--	--	--	
	4	78	164	279	7	47	48	46	44	41	36	22	--	--	35	31	32	29	30	25	--	--	--	25	20	19	-	-	-	--	--	--
	6	116	246	418	15	52	52	50	49	44	39	26	--	22	39	35	36	33	34	29	--	--	--	29	24	23	20	18	20	--	--	--
	8	155	328	558	26	56	56	54	52	48	42	30	24	26	42	38	38	35	37	31	21	--	--	32	27	26	23	21	23	--	--	--
10	194	410	697	41	60	60	58	56	51	45	34	28	30	44	40	41	38	39	34	23	--	--	34	29	28	25	23	25	--	--	--	
200	2	61	129	219	2	39	34	37	34	30	23	--	--	--	29	24	23	23	18	--	--	--	19	-	-	-	-	--	--	--		
	4	122	258	439	6	48	44	46	42	37	31	20	--	--	36	31	31	29	30	25	--	--	--	26	22	21	18	-	--	--	--	
	6	183	387	658	14	54	51	52	47	42	36	26	--	20	40	35	35	33	34	29	--	--	--	30	26	25	22	20	21	--	--	--
	8	244	516	878	25	58	55	56	51	46	40	31	23	25	43	38	38	36	37	31	21	--	--	33	29	28	25	22	24	--	--	--
10	305	645	1097	39	61	59	60	54	50	43	34	27	30	45	40	40	38	39	34	23	--	--	35	31	30	27	25	26	--	--	--	
250	2	96	203	345	1	41	43	42	39	34	30	--	--	--	29	24	24	23	23	18	--	--	--	19	-	-	-	-	--	--	--	
	4	192	406	690	6	50	51	50	45	40	35	25	--	20	36	31	31	29	30	25	--	--	--	26	21	21	18	-	--	--	--	
	6	288	609	1035	13	56	56	55	50	44	39	30	23	26	40	35	35	33	34	29	--	--	--	30	25	25	22	20	21	--	--	--
	8	383	812	1380	23	60	60	59	53	47	43	34	28	30	43	38	38	36	37	31	21	--	--	33	28	28	25	23	24	--	--	--
10	479	1015	1725	36	63	63	62	56	50	45	37	32	34	45	40	40	38	39	34	23	--	--	35	31	31	27	25	26	--	--	--	
315	2	153	324	550	1	42	45	41	41	38	33	--	--	--	30	24	24	23	23	19	--	--	--	21	18	18	-	-	-	--	--	--
	4	306	648	1101	5	52	52	48	47	43	38	26	--	21	37	31	31	30	30	26	--	--	--	28	25	25	22	18	19	--	--	--
	6	459	971	1651	12	58	57	54	52	48	42	31	24	27	41	35	35	34	34	30	--	--	--	32	29	29	26	22	23	--	--	--
	8	612	1295	2202	22	63	61	58	56	52	46	35	29	31	44	38	38	36	37	32	21	--	--	35	32	32	29	25	26	--	--	--
10	764	1619	2752	34	67	64	62	59	55	50	39	34	35	46	40	40	39	39	35	23	--	--	38	34	34	31	27	28	--	--	--	
355	2	195	412	701	1	42	52	45	45	40	38	24	--	21	30	24	24	23	23	19	--	--	--	22	19	19	-	-	-	--	--	--
	4	389	824	1401	5	53	56	51	50	43	42	29	24	26	37	31	31	30	30	26	--	--	--	29	26	26	23	18	20	--	--	--
	6	584	1236	2102	12	59	60	56	54	46	45	33	28	30	41	35	35	34	34	30	--	--	--	33	30	30	27	23	24	--	--	--
	8	779	1649	2803	21	64	63	60	57	50	48	37	32	33	44	38	38	37	37	33	21	--	--	36	33	33	30	25	27	--	--	--
10	973	2061	3503	33	68	66	64	61	53	52	41	36	37	46	40	40	39	39	35	24	--	--	38	35	35	32	28	29	--	--	--	
400	2	248	524	891	1	43	54	46	46	42	36	26	21	24	30	24	24	23	23	19	--	--	--	22	19	19	-	-	-	--	--	--
	4	495	1049	1783	5	54	58	52	51	45	40	31	26	28	37	31	31	30	30	26	--	--	--	29	26	26	24	19	20	--	--	--
	6	743	1573	2674	11	60	62	57	55	48	43	35	30	32	41	35	35	34	34	30	--	--	--	33	30	30	28	23	24	--	--	--
	8	990	2097	3565	20	65	65	61	58	52	46	39	34	36	44	38	37	37	37	33	21	--	--	36	33	33	31	26	27	--	--	--
10	1238	2621	4456	32	69	68	65	62	55	50	42	37	39	46	40	40	39	39	35	23	--	--	39	36	36	33	28	29	--	--	--	

1. Sound data is determined in a reverberation room at an independent sound laboratory, according to ISO 3741 and ISO 5135 standards.
2. L_w in dB/Oct. (re 1pW) are sound power levels for discharge sound and case radiated sound. Figures less than 17 dB are indicated by "--".
3. The discharge sound pressure levels are determined with the assumptions as mentioned in table 1 for downstream ductwork including a diffuser with insulated plenum box.
4. The radiated sound pressure levels are determined

5. L_p values are including a room absorption of 10 dB/Oct.
6. dB(A), NC and NR index figures are sound pressure levels. Figures less than 20 are indicated by "--".
7. Δp_s is static pressure drop across VAV air volume control terminal with damper fully open.
8. For non standard applications and/or selections, please contact our technical staff.

Table 1: Assumptions for additional attenuation

Hz	125	250	500	1K	2K	4K
Discharge (dB)	5	10	20	30	30	25
Radiated (dB)	2	5	10	15	15	20

Circular VAV and CAV air volume control terminals

Type NAOBOOB NBOBOOB

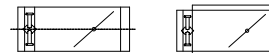

Sound data $\Delta p = 250 \text{ Pa}$

Model	data referring to inlet spigot				min. Δp_s	$\Delta p = 250 \text{ Pa}$																											
						discharge sound						radiated sound single wall						radiated sound double wall															
	velocity		air volume			L_w in dB/Oct. (re 1pW)						Lp values			L_w in dB/Oct. (re 1pW)						Lp values			L_w in dB/Oct. (re 1pW)						Lp values			
						125 Hz	250 Hz	500 Hz	1000 Hz	2000 Hz	4000 Hz	dB(A)	NC	NR	125 Hz	250 Hz	500 Hz	1000 Hz	2000 Hz	4000 Hz	dB(A)	NC	NR	125 Hz	250 Hz	500 Hz	1000 Hz	2000 Hz	4000 Hz	dB(A)	NC	NR	
m/s	l/s	CFM	m ³ /h	Pa	dB									dB									dB										
100	2	15	31	53	2	45	48	45	43	40	29	21	--	--	26	23	26	27	30	28	--	--	--	21	-	-	-	-	-	--	--	--	
	4	29	62	106	8	51	53	51	48	45	35	27	20	23	33	30	33	34	37	35	--	--	--	28	22	18	-	-	18	--	--	--	
	6	44	94	160	17	55	57	54	52	49	40	31	25	27	37	34	37	38	41	39	21	--	--	32	26	22	20	20	22	--	--	--	
	8	59	125	213	30	58	60	57	55	53	44	34	28	31	40	37	40	41	44	42	24	--	22	35	29	25	23	23	25	--	--	--	
	10	74	156	266	47	60	63	60	57	56	47	36	32	33	42	39	42	43	46	44	26	22	24	38	32	28	25	25	27	--	--	--	
125	2	23	49	84	2	43	47	46	43	40	33	20	--	--	35	31	31	28	30	24	--	--	--	22	17	-	-	-	--	--	--		
	4	47	99	168	7	50	53	51	49	45	38	26	20	23	41	38	38	35	37	31	20	--	--	29	24	21	18	-	19	--	--	--	
	6	70	149	253	16	54	57	55	53	48	41	30	25	27	45	42	42	39	41	35	24	--	--	33	28	25	22	21	23	--	--	--	
	8	94	198	337	28	58	60	58	56	51	45	34	29	31	48	45	45	42	44	38	27	--	22	36	31	28	25	24	26	--	--	--	
	10	117	248	421	44	61	63	61	58	54	48	37	32	34	50	47	47	44	46	40	29	22	24	39	34	31	27	26	28	--	--	--	
160	2	39	82	139	2	42	47	46	44	43	40	20	--	--	35	31	31	28	30	24	--	--	--	24	19	18	-	-	-	--	--	--	
	4	78	164	279	7	50	53	52	50	47	43	26	20	23	41	38	38	35	37	31	20	--	--	31	26	25	20	18	20	--	--	--	
	6	116	246	418	15	55	57	55	54	50	46	31	24	27	45	42	42	39	41	35	24	--	--	35	30	29	24	22	24	--	--	--	
	8	155	328	558	26	59	60	59	57	53	48	34	28	30	48	45	45	42	44	38	27	--	22	38	33	32	27	25	27	--	--	--	
	10	194	410	697	41	62	63	61	59	55	50	37	32	33	50	47	47	44	46	40	29	22	24	40	35	34	29	27	29	--	--	--	
200	2	61	129	219	2	43	38	41	39	36	30	--	--	--	36	31	31	29	30	24	--	--	--	25	21	20	-	-	-	--	--	--	
	4	122	258	439	6	52	49	50	47	43	37	24	--	--	--	43	38	38	36	37	31	21	--	--	32	28	27	22	19	21	--	--	--
	6	183	387	658	14	57	55	56	51	47	42	30	22	24	47	42	42	40	41	35	25	--	--	36	32	31	26	23	25	--	--	--	
	8	244	516	878	25	61	59	60	55	51	45	34	27	29	50	45	45	43	44	38	28	--	22	39	35	34	29	26	28	--	--	--	
	10	305	645	1097	39	64	63	63	58	54	48	38	31	33	52	47	47	45	46	40	30	22	24	41	37	36	31	29	30	--	--	--	
250	2	96	203	345	1	44	47	46	44	41	37	21	--	--	36	31	31	29	30	24	--	--	--	25	20	20	-	-	-	--	--	--	
	4	192	406	690	6	53	55	54	50	46	42	29	23	25	43	38	38	36	37	31	21	--	--	32	27	27	22	20	21	--	--	--	
	6	288	609	1035	13	59	60	59	54	50	46	34	28	31	47	42	42	40	41	35	25	--	--	36	31	31	26	24	25	--	--	--	
	8	383	812	1380	23	63	64	62	57	53	48	38	33	35	50	45	45	43	44	38	28	--	22	39	34	34	29	27	28	--	--	--	
	10	479	1015	1725	36	66	67	65	60	55	51	41	36	38	52	47	47	45	46	40	30	22	24	41	37	37	31	29	30	--	--	--	
315	2	153	324	550	1	45	50	45	46	45	40	23	--	20	37	31	31	29	30	25	--	--	--	27	24	24	19	-	-	--	--	--	
	4	306	648	1101	5	54	56	52	52	50	44	30	24	26	43	37	38	36	36	32	21	--	--	34	31	31	26	22	23	--	--	--	
	6	459	971	1651	12	60	60	57	56	53	48	34	28	31	47	41	42	40	40	36	25	--	--	38	35	35	30	26	27	--	--	--	
	8	612	1295	2202	22	65	64	61	59	56	51	38	33	34	50	44	44	43	43	39	27	--	21	41	38	38	33	29	30	--	--	--	
	10	764	1619	2752	34	69	67	64	62	59	54	41	36	37	52	46	47	45	45	41	30	21	23	44	40	40	35	31	32	22	--	--	
355	2	195	412	701	1	45	57	50	51	47	47	29	24	27	37	31	31	30	30	26	--	--	--	28	25	25	20	-	-	--	--	--	
	4	389	824	1401	5	55	61	56	55	50	49	33	29	31	44	38	38	37	37	33	21	--	--	35	32	32	27	22	24	--	--	--	
	6	584	1236	2102	12	61	64	60	58	52	51	37	32	34	48	42	42	41	41	37	25	--	--	39	36	36	31	26	28	--	--	--	
	8	779	1649	2803	21	66	66	63	61	55	54	40	35	37	50	45	45	44	44	40	28	--	22	42	39	39	34	29	31	20	--	--	--
	10	973	2061	3503	33	70	69	66	64	57	56	43	38	39	53	47	47	46	46	42	30	22	24	44	41	41	36	32	33	23	--	--	--
400	2	248	524	891	1	46	59	51	52	49	45	31	27	29	37	31	30	30	30	26	--	--	--	28	25	25	21	-	17	--	--	--	
	4	495	1049	1783	5	56	63	57	56	52	47	35	31	33	44	37	37	37	36	33	21	--	--	35	32	32	28	23	24	--	--	--	
	6	743	1573	2674	11	62	66	61	59	54	49	39	35	36	48	41	41	41	40	37	25	--	--	39	36	36	32	27	28	--	--	--	
	8	990	2097	3565	20	67	68	64	62	57	52	42	38	39	50	44	44	43	43	39	27	--	21	42	39	39	35	30	31	21	--	--	--
	10	1238	2621	4456	32	71	71	67	65	59	54	45	41	42	53	46	46	46	45	42	30	21	23	45	42	42	37	32	33	23	--	--	--

1. Sound data is determined in a reverberation room at an independent sound laboratory, according to ISO 3741 and ISO 5135 standards.
2. L_w in dB/Oct. (re 1pW) are sound power levels for discharge sound and case radiated sound. Figures less than 17 dB are indicated by "--".
3. The discharge sound pressure levels are determined with the assumptions as mentioned in table 1 for downstream ductwork including a diffuser with insulated plenum box.
4. The radiated sound pressure levels are determined

5. L_p values are including a room absorption of 10 dB/Oct.
6. dB(A), NC and NR index figures are sound pressure levels. Figures less than 20 are indicated by "--".
7. Δp_s is static pressure drop across VAV air volume control terminal with damper fully open.
8. For non standard applications and/or selections, please contact our technical staff.

Table 1: Assumptions for additional attenuation

Hz	125	250	500	1K	2K	4K
Discharge (dB)	5	10	20	30	30	25
Radiated (dB)	2	5	10	15	15	20

